



**TUBULAR FAN**  
Fixed through support.

**EXTRACTEUR TUBULAIRE**  
Assujetissement avec support.

## MT-100/125/150

TUBULAR FAN / EXTRACTEUR TUBULAIRE

- Tubular fan for installation in rigid or flexible piping.
- Easy installation, con soporte opcional.
- Silent.
- "Maximum safety" 12 volt version.

- *Extracteur tubulaire pour des installations de conduits rigides ou souples*
- *Installation facile.*
- *Silencieux.*
- *Version 12 volts "haute sécurité".*

MT-100/125/150		MT-100	MT-100 T	MT-125	MT-125 T	MT-150	MT-150 T
	<b>STANDARD</b> Works with light switch. <i>Fonctionne avec l'interrupteur lumière.</i>	●		●		●	
	<b>TIMER</b> Adjustable electronic timer. <i>Minuterie électronique réglable.</i>		●		●		●
	Wall kit <i>Kit mur</i>	●	●	●	●	●	●
	Fixed grille <i>Grille fixe</i>	●	●	●	●	●	●
	Over-pressure grille <i>Grille sur-pression</i>	●	●	●	●	●	●
	Support <i>Support</i>	●	●	●	●	●	●
<b>FINISHES AVAILABLE / FINITIONS DISPONIBLES</b>	WHITE/ BLANC	●	●	●	●	●	●

● FEATURES / CARACTÉRISTIQUES

● ACCESSORIES AVAILABLE IN THE RANGE / ACCESSOIRES DISPONIBLES POUR LA GAMME



### PRESSURE AND FLOW / PRESSION ET DÉBIT

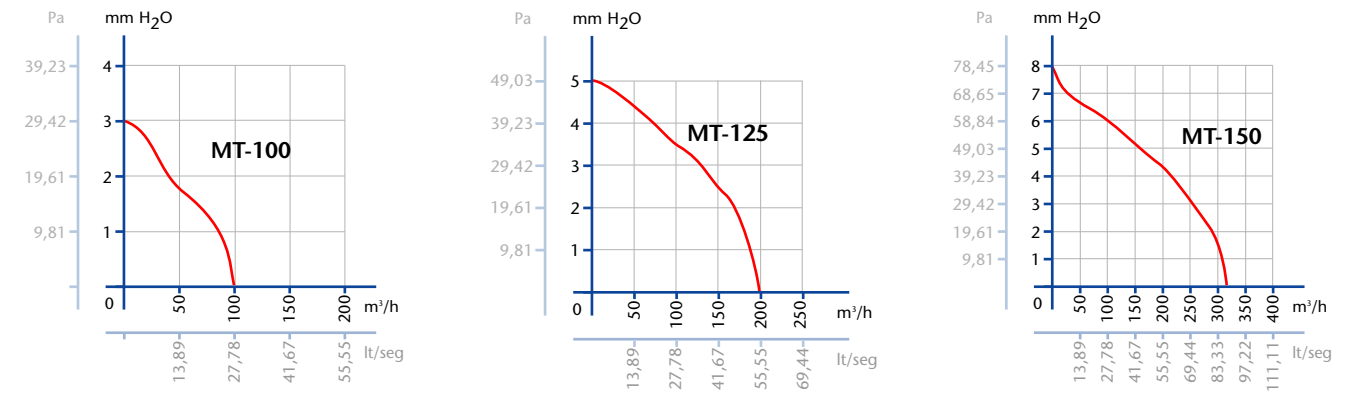

### SIZES mm / MESURES mm

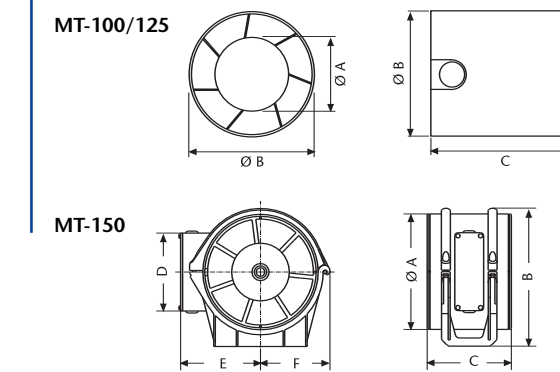

	$\varnothing A$	B	C	D	E	F
MT-100/T	60	97	92	-	-	-
MT-125/T	65	118	96	-	-	-
MT-150/T	148	177	108	100	99,5	89,2

MT	$\varnothing$ mm			230V-50Hz	RPM	W	MÁX.		db(A)	Kg.		
	100	125	150				m <sup>3</sup> /h	mm H <sub>2</sub> O				
MT-100/T	●			●	2500	15	98	3	41	0,41	●	●
MT-125/T		●		●	2450	20	190	5	43	0,60	●	●
MT-150/T			●	●	2100	25	320	8	45	1,20	●	●

### INSTALLATION / INSTALLATION

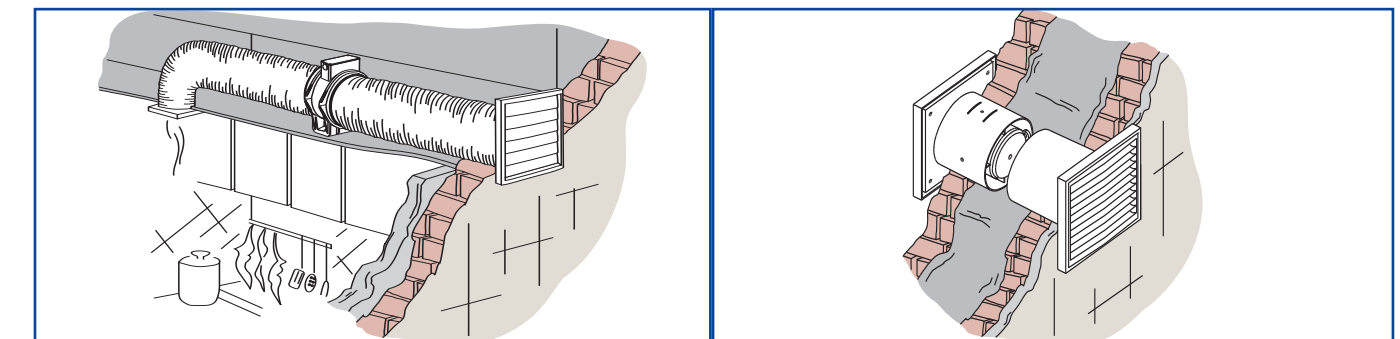

- In-Line Kit.
- Installation Kit In-Line.

- Wall inserted.
- Installation encastré sur un mur.